

PVC COATED CONDUIT AND ACCESSORIES



PVC COATED RIGID CONDUIT

Hot-dip galvanized steel or aluminum conduit
 40 mil PVC coating on exterior
 2 mil grey urethane coating on interior and threads
 Color-coded thread protectors
 Couplings shipped with conduit are packaged separately



Cat. No .		Trade Size	Metric Size	Wall Thickness With PVC(in)	OD With PVC(in)	ID (in)	LENGTH Without Coupling
Steel	Alum.						
RSC15P	RAC15P	1/2"	16	0.14	0.92	0.63	9' 11 1/4"
RSC20P	RAC20P	3/4"	21	0.15	1.13	0.84	9' 11 1/4"
RSC25P	RAC25P	1"	27	0.17	1.40	1.06	9' 11"
RSC32P	RAC32P	1-1/4"	35	0.17	1.74	1.39	9' 11"
RSC40P	RAC40P	1-1/2"	41	0.18	1.98	1.62	9' 11"
RSC50P	RAC50P	2"	53	0.19	2.46	2.08	9' 11"
RSC65P	RAC65P	2-1/2"	63	0.23	2.96	2.49	9' 10 1/2"
RSC80P	RAC80P	3"	78	0.25	3.58	3.09	9' 10 1/2"
RSC90P	RAC90P	3-1/2"	91	0.26	4.08	3.57	9' 10 1/4"
RSC100P	RAC100P	4"	103	0.27	4.58	4.05	9' 10 1/4"
RSC125P	RAC125P	5"	129	0.29	5.64	5.07	9' 10"
RSC150P	RAC150P	6"	155	0.31	6.71	6.09	9' 10"

PVC COATED RIGID COUPLING

2 mil grey urethane coating on interior and threads
 40 mil PVC coating bonded to exterior
 Straight threads (NPSL)
 Molded external ribs on 1/2"-4"
 Sealing sleeves on both ends



Cat. No .		Trade Size	Metric Size	Min. Length Of Metal(in)	PVC(in)	Total Min. Length Including Sleeve(in)
Steel	Alum.					
GC15P	AC15P	1/2"	16	1.50		3.75
GC20P	AC20P	3/4"	21	1.53		3.75
GC25P	AC25P	1"	27	1.91		4.94
GC32P	AC32P	1-1/4"	35	1.91		5.50
GC40P	AC40P	1-1/2"	41	1.91		5.75
GC50P	AC50P	2"	53	1.94		5.94
GC65P	AC65P	2-1/2"	63	2.88		6.88
GC80P	AC80P	3"	78	3.03		7.03
GC90P	AC90P	3-1/2"	91	3.09		7.09
GC100P	AC100P	4"	103	3.19		7.19
GC125P	AC125P	5"	129	3.37		7.37
GC150P	AC150P	6"	155	3.44		7.44

PVC COATED 90° STANDARD ELBOW

Hot-dip galvanized steel or aluminum
 2 mil grey urethane coating on interior and threads
 40 mil PVC coating bonded to exterior
 Available in standard sizes 90°, 60°, 45°, 30° bends

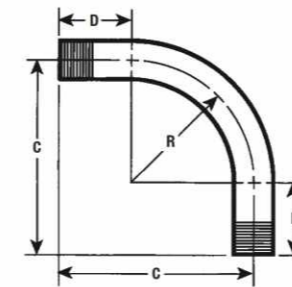

Cat. No .		Trade Size	Metric Size	Min Radius R (in)	Offset C(in)	Straight End D(in)
Steel	Alum.					
RSCE9015P	RACE9015P	1/2"	16	4.00	6.96	2.50
RSCE9020P	RACE9020P	3/4"	21	4.50	7.73	2.50
RSCE9025P	RACE9025P	1"	27	5.75	9.36	3.00
RSCE9032P	RACE9032P	1-1/4"	35	7.25	11.38	3.25
RSCE9040P	RACE9040P	1-1/2"	41	8.25	12.76	3.50
RSCE9050P	RACE9050P	2"	53	9.50	15.01	4.25
RSCE9065P	RACE9065P	2-1/2"	63	10.50	17.11	5.00
RSCE9080P	RACE9080P	3"	78	13.00	20.33	5.50
RSCE9090P	RACE9090P	3-1/2"	91	15.00	23.38	6.25
RSCE90100P	RACE90100P	4"	103	16.00	25.40	7.00
RSCE90125P	RACE90125P	5"	129	24.00	37.86	11.00
RSCE90150P	RACE90150P	6"	155	30.00	45.99	12.50

PVC COATED LARGE RADIUS ELBOW

Hot-dip galvanized steel or aluminum
 2 mil grey urethane coating on interior and threads
 40 mil PVC coating bonded to exterior
 Available in standard sizes 90°, 60°, 45°, 30° bends

Cat. No .		Trade Size	Metric Size	Min Radius R (in)	Offset C(in)	Straight End D(in)
Steel	Alum.					
LG12R_90P	LGA12R_90P	1"-2 1/2"	27-63	12.00	21.00	9.00
LG15R_90P	LGA15R_90P	1"-3"	27-78	15.00	24.00	9.00
LG18R_90P	LGA18R_90P	1"-4"	27-103	18.00	32.00	10.00
LG24R_90P	LGA24R_90P	1"-4"	27-103	24.00	35.00	11.00
LG30R_90P	LGA30R_90P	1"-6"	27-155	30.00	41.00	11.00
LG36R_90P	LGA36R_90P	1"-6"	27-155	36.00	47.00	11.00
LG42R_90P	LGA42R_90P	1"-6"	27-155	42.00	54.00	12.00
LG48R_90P	LGA48R_90P	1"-6"	27-155	48.00	60.00	12.00
LG60R_90P	LGA60R_90P	1"-6"	27-155	60.00	72.00	12.00

PVC COATED CONDUIT NIPPLE

Made from PVC-coated Hot-dip galvanized steel or aluminum conduit
 2 mil grey urethane on interior and threads
 40 mil PVC coating on exterior
 Close nipples are coated only in urethane



steel

SIZE	NIPPLE LENGTH										
	CLOSE	2"	2-1/2"	3"	3-1/2"	4"	5"	6"	8"	10"	12"
1/2	GN15CLP	GN1520P	GN1525P	GN1530P	GN1535P	GN1540P	GN1550P	GN1560P	GN1580P	GN15100P	GN15120P
3/4	GN20CLP	GN2020P	GN2025P	GN2030P	GN2035P	GN2040P	GN2050P	GN2060P	GN2080P	GN20100P	GN20120P
1	GN25CLP	GN2520P	GN2525P	GN2530P	GN2535P	GN2540P	GN2550P	GN2560P	GN2580P	GN25100P	GN25120P
1-1/4	GN32CLP	GN3220P	GN3225P	GN3230P	GN3235P	GN3240P	GN3250P	GN3260P	GN3280P	GN32100P	GN32120P
1-1/2	GN40CLP	GN4020P	GN4025P	GN4030P	GN4035P	GN4040P	GN4050P	GN4060P	GN4080P	GN40100P	GN40120P
2	GN50CLP		GN5025P	GN5030P	GN5035P	GN5040P	GN5050P	GN5060P	GN5080P	GN50100P	GN50120P
2-1/2	GN65CLP			GN6530P	GN6535P	GN6540P	GN6550P	GN6560P	GN6580P	GN65100P	GN65120P
3	GN80CLP				GN8035P	GN8040P	GN8050P	GN8060P	GN8080P	GN80100P	GN80120P
3-1/2	GN90CLP					GN9040P	GN9050P	GN9060P	GN9080P	GN90100P	GN90120P
4	GN100CLP					GN10040P	GN10050P	GN10060P	GN10080P	GN100100P	GN100120P
5	GN125CLP						GN12550P	GN12560P	GN12580P	GN125100P	GN125120P
6	GN150CLP							GN15060P	GN15080P	GN150100P	GN150120P

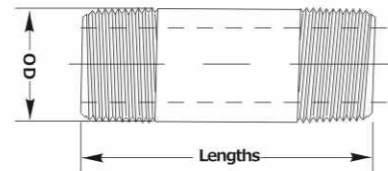

aluminum

SIZE	NIPPLE LENGTH										
	CLOSE	2"	2-1/2"	3"	3-1/2"	4"	5"	6"	8"	10"	12"
1/2	AN15CLP	AN1520P	AN1525P	AN1530P	AN1535P	AN1540P	AN1550P	AN1560P	AN1580P	AN15100P	AN15120P
3/4	AN20CLP	AN2020P	AN2025P	AN2030P	AN2035P	AN2040P	AN2050P	AN2060P	AN2080P	AN20100P	AN20120P
1	AN25CLP	AN2520P	AN2525P	AN2530P	AN2535P	AN2540P	AN2550P	AN2560P	AN2580P	AN25100P	AN25120P
1-1/4	AN32CLP	AN3220P	AN3225P	AN3230P	AN3235P	AN3240P	AN3250P	AN3260P	AN3280P	AN32100P	AN32120P
1-1/2	AN40CLP	AN4020P	AN4025P	AN4030P	AN4035P	AN4040P	AN4050P	AN4060P	AN4080P	AN40100P	AN40120P
2	AN50CLP		AN5025P	AN5030P	AN5035P	AN5040P	AN5050P	AN5060P	AN5080P	AN50100P	AN50120P
2-1/2	AN65CLP			AN6530P	AN6535P	AN6540P	AN6550P	AN6560P	AN6580P	AN65100P	AN65120P
3	AN80CLP				AN8035P	AN8040P	AN8050P	AN8060P	AN8080P	AN80100P	AN80120P
3-1/2	AN90CLP					AN9040P	AN9050P	AN9060P	AN9080P	AN90100P	AN90120P
4	AN100CLP					AN10040P	AN10050P	AN10060P	AN10080P	AN100100P	AN100120P
5	AN125CLP						AN12550P	AN12560P	AN12580P	AN125100P	AN125120P
6	AN150CLP							AN15060P	AN15080P	AN150100P	AN150120P



PVC COATED ORDINARY LOCATION PRODUCTS



PVC COATED PULLING ELBOW LBD

2 mil grey urethane coating on interior and threads
 40 mil PVC coating bonded to exterior
 Sealing sleeves on all conduit openings
 Shipped with cover

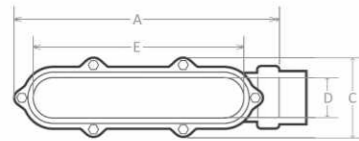
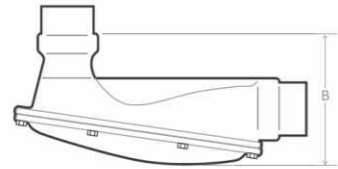

Cat.#		TradeSize	A	B	C	D	E
Ferrous	Alum.						
LBD15P	LBD15AP	1/2"	5.00	2.35	1.39	1.00	3.34
LBD20P	LBD20AP	3/4"	6.25	2.67	1.64	1.25	4.53
LBD25P	LBD25AP	1"	6.25	2.98	1.89	1.50	4.34
LBD32P	LBD32AP	1-1/4"	8.63	4.29	3.58	1.81	7.19
LBD40P	LBD40AP	1-1/2"	12.44	5.48	4.71	2.63	10.88
LBD50P	LBD50AP	2"	12.44	5.48	4.71	2.63	10.88
LBD65P	LBD65AP	2-1/2"	19.69	9.60	5.71	3.00	15.75
LBD80P	LBD80AP	3"	19.69	9.60	5.71	3.00	15.75
LBD90P	-	3-1/2"	20.88	10.92	7.75	4.75	19.89
-	LBD90AP	3-1/2"	27.81	11.92	7.21	4.00	24.00
LBD100P	-	4"	20.88	10.92	7.75	4.75	19.89
-	LBD100AP	4"	27.81	11.92	7.21	4.00	24.00

PVC COATED MOGUL STYLE CONDUIT BODY

2 mil grey urethane coating on interior and threads
 40 mil PVC coating bonded to exterior
 Sealing sleeves on all conduit openings
 Shipped with cover

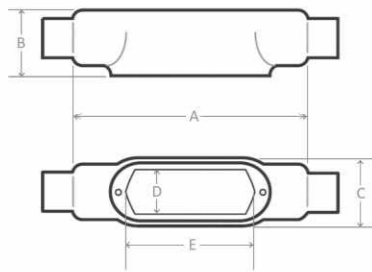

Cat.#		TradeSize	A	B	C	D	E
Ferrous	Alum.						
BC25P	BC25AP	1"	9.56	1.92	2.27	1.88	6.00
BC32P	BC32AP	1-1/4"	9.56	2.35	2.27	1.88	6.00
BC40P	BC40AP	1-1/2"	13.75	2.60	3.08	2.63	10.00
BC50P	BC50AP	2"	13.75	3.17	3.08	2.63	10.00
BC65P	BC65AP	2-1/2"	18.38	3.67	4.33	3.81	15.00
BC80P	BC80AP	3"	18.38	4.42	4.33	3.81	15.00
BC90P	BC90AP	3-1/2"	23.75	4.92	5.33	4.75	20.00
BC100P	BC100AP	4"	25.25	5.42	5.33	4.75	20.00

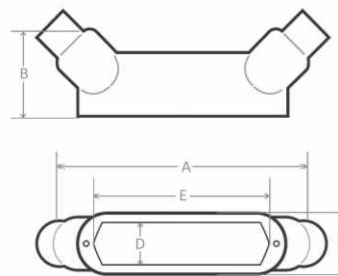

Cat.#		TradeSize	A	B	C	D	E
Ferrous	Alum.						
BUB25P	BUB25AP	1"	9.19	2.73	2.27	1.88	6.00
BUB32P	BUB32AP	1-1/4"	9.31	3.23	2.27	1.88	6.00
BUB40P	BUB40AP	1-1/2"	13.50	3.54	3.08	2.63	10.00
BUB50P	BUB50AP	2"	13.50	4.17	3.08	2.63	10.00
BUB65P	BUB65AP	2-1/2"	17.75	4.85	4.33	3.81	15.00
BUB80P	BUB80AP	3"	17.88	6.57	4.33	3.81	15.00
BUB90P	BUB90AP	3-1/2"	23.38	6.42	5.33	4.75	20.00
BUB100P	BUB100AP	4"	23.75	6.85	5.33	4.75	20.00

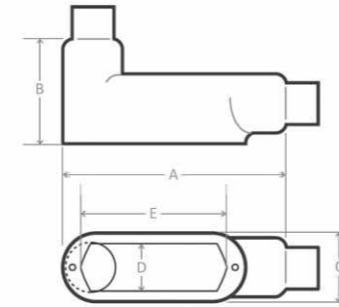

BLB

Cat.#		TradeSize	A	B	C	D	E
Ferrous	Alum.						
BLB25P	BLB25AP	1"	8.63	2.88	2.27	1.88	6.00
BLB32P	BLB32AP	1-1/4"	8.63	3.32	2.27	1.88	6.00
BLB40P	BLB40AP	1-1/2"	12.73	3.67	3.08	2.63	10.00
BLB50P	BLB50AP	2"	12.73	4.23	3.08	2.63	10.00
BLB65P	BLB65AP	2-1/2"	16.95	5.13	4.33	3.81	15.00
BLB80P	BLB80AP	3"	16.95	5.88	4.33	3.81	15.00
BLB90P	BLB90AP	3-1/2"	22.17	6.54	5.33	4.75	20.00
BLB100P	BLB100AP	4"	22.17	7.04	5.33	4.75	20.00

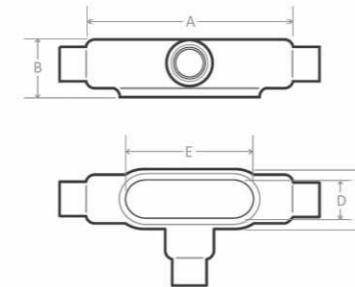

BT

Cat.#		TradeSize	A	B	C	D	E
Ferrous	Alum.						
BT25P	BT25AP	1"	9.56	1.92	4.20	1.88	6.00
BT32P	BT32AP	1-1/4"	9.56	2.35	4.45	1.88	6.00
BT40P	BT40AP	1-1/2"	13.75	2.60	5.60	2.63	10.00
BT50P	BT50AP	2"	13.75	3.17	6.10	2.63	10.00
BT80P	BT80AP	3"	18.38	4.42	7.76	3.81	15.00

BG COVER

Cat.#		Description
Ferrous	Alum.	
BGC32P	BGC32AP	1-1/4 BG COVER MOGUL
BGC50P	BGC50AP	1 1/2-2 BG COVER MOGUL
BGC80P	BGC80P	2 1/2-3 BG COVER MOGUL
BGC100P	BGC100AP	3 1/2-4 BG COVER MOGUL

PVC COATED CONDUIT BODY

2 mil grey urethane coating on interior and threads
 40 mil PVC coating bonded to exterior
 Sealing sleeves on all conduit openings
 Shipped with cover

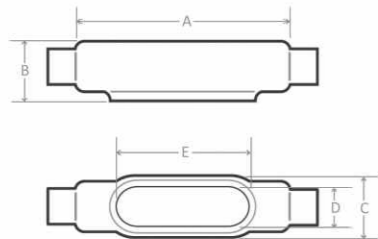
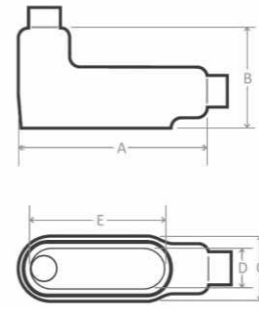

C FORM 7

Cat.#		TradeSize	A	B	C	D	E
Ferrous	Alum.						
C17P	C17AP	1/2"	5.45	1.40	1.45	0.95	3.20
C27P	C27AP	3/4"	6.05	1.60	1.65	1.15	3.80
C37P	C37AP	1"	6.75	1.90	1.80	1.35	4.55
C47P	C47AP	1-1/4"	7.30	2.30	2.20	1.80	5.00
C57P	C57AP	1-1/2"	8.60	2.60	2.45	2.05	5.45
C67P	C67AP	2"	9.50	3.20	3.05	2.45	6.40
C77P	C77AP	2-1/2"	12.10	3.65	4.25	3.60	8.40
C87P	C87AP	3"	12.10	4.40	4.25	3.60	8.40

C FORM 8

Cat.#		TradeSize	A	B	C	D	E
Ferrous	Alum.						
C18P	-	1/2"	5.53	1.44	1.38	1.00	3.31
C28P	-	3/4"	6.28	1.73	1.46	1.19	3.94
C38P	-	1"	7.31	1.98	1.83	1.38	4.56
C48P	-	1-1/4"	8.50	2.42	2.27	1.75	5.31
C58P	-	1-1/2"	10.38	2.82	2.83	2.13	6.50
C68P	-	2"	12.25	3.60	3.83	3.00	8.56
C78P	-	2-1/2"	15.63	4.48	5.08	4.25	10.88
C88P	-	3"	15.63	4.85	5.08	4.25	10.88

C FORM 9

Cat.#		TradeSize	A	B	C	D	E
Ferrous	Alum.						
-	C19P	1/2"	5.00	1.38	1.38	1.19	3.31
-	C29P	3/4"	5.69	1.63	1.56	1.38	3.94
-	C39P	1"	6.59	1.88	1.75	1.50	4.56
-	C49P	1-1/4"	7.50	2.50	2.19	1.94	5.31
-	C59P	1-1/2"	8.25	2.75	2.50	2.25	6.00
-	C69P	2"	10.50	3.44	3.19	2.88	8.06
-	C79P	2-1/2"	15.63	4.44	5.00	4.25	10.88
-	C89P	3"	15.63	4.81	5.00	4.25	10.88
-	C99P	3-1/2"	18.75	5.69	6.25	5.44	13.44
-	C109P	4"	18.75	5.94	6.25	5.44	13.44

LB FORM 7

Cat.#		TradeSize	A	B	C	D	E
Ferrous	Alum.						
LB17P	LB17AP	1/2"	4.60	2.20	1.46	0.94	3.19
LB27P	LB27AP	3/4"	5.24	2.50	1.64	1.13	3.81
LB37P	LB37AP	1"	6.04	2.88	1.83	1.38	4.50
LB47P	LB47AP	1-1/4"	6.54	3.31	2.27	1.75	5.00
LB57P	LB57AP	1-1/2"	7.17	3.69	2.52	1.94	5.44
LB67P	LB67AP	2"	8.17	4.25	3.08	2.44	6.38
LB77P	LB77AP	2-1/2"	10.54	5.13	4.33	3.56	8.38
LB87P	LB87AP	3"	10.54	5.88	4.33	3.56	8.38
LB97P	LB97AP	3-1/2"	12.85	6.56	5.33	4.50	10.25
LB107P	LB107AP	4"	12.85	7.06	5.33	4.50	10.25

LB FORM 8

Cat.#		TradeSize	A	B	C	D	E
Ferrous	Alum.						
LB18P	-	1/2"	4.98	2.22	1.46	1.00	3.31
LB28P	-	3/4"	5.60	2.44	1.64	1.19	3.94
LB38P	-	1"	6.51	2.81	1.83	1.38	4.56
LB48P	-	1-1/4"	7.57	3.34	2.27	1.75	5.31
LB58P	-	1-1/2"	7.17	4.03	2.83	2.13	6.50
LB68P	-	2"	11.04	4.81	3.83	3.00	8.56
LB78P	-	2-1/2"	13.98	6.13	5.08	4.25	10.88
LB88P	-	3"	13.98	6.50	5.08	4.25	10.88
LB98P	-	3-1/2"	16.88	7.56	6.25	5.44	13.44
LB108P	-	4"	16.88	7.81	6.25	5.44	13.44

LB FORM 9

Cat.#		TradeSize	A	B	C	D	E
Ferrous	Alum.						
-	LB19P	1/2"	4.59	2.13	1.38	1.19	3.31
-	LB29P	3/4"	5.29	2.41	1.64	1.38	3.94
-	LB39P	1"	6.13	2.84	1.83	1.50	4.56
-	LB49P	1-1/4"	7.07	3.47	2.27	1.94	5.31
-	LB59P	1-1/2"	7.79	3.75	2.58	2.25	6.00
-	LB69P	2"	10.07	4.47	3.27	2.88	8.06
-	LB79P	2-1/2"	13.98	6.13	5.08	4.25	10.88
-	LB89P	3"	13.98	6.50	5.08	4.25	10.88
-	LB99P	3-1/2"	16.88	7.56	6.33	5.44	13.44
-	LB109P	4"	16.88	7.81	6.33	5.44	13.44

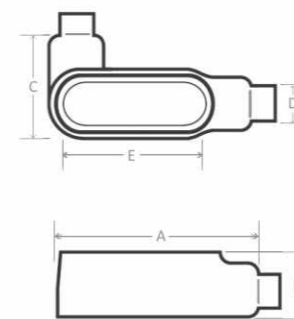

LL FORM 7

Cat.#		TradeSize	A	B	C	D	E
Ferrous	Alum.						
LL17P	LL17AP	1/2"	4.60	1.42		0.94	3.19
LL27P	LL27AP	3/4"	5.23	1.67	2.29	1.13	3.81
LL37P	LL37AP	1"	6.04	1.92	2.48	1.38	4.50
LL47P	LL47AP	1-1/4"	6.54	2.35	2.79	1.75	5.00
LL57P	LL57AP	1-1/2"	7.17	2.60	3.23	1.94	5.44
LL67P	LL67AP	2"	8.17	3.17	3.60	2.44	6.38
LL77P	LL77AP	2-1/2"	10.54	3.67	4.17	3.56	8.38
LL87P	LL87AP	3"	10.54	4.42	5.79	3.56	8.38
LL97P	LL97AP	3-1/2"	12.73	4.92	5.79	4.50	10.25
LL107P	LL107AP	4"	12.73	5.42	6.98	4.50	10.25

LL FORM 8

Cat.#		TradeSize	A	B	C	D	E
Ferrous	Alum.						
LL18P	-	1/2"	4.94	1.48	2.20	1.00	3.31
LL28P	-	3/4"	5.56	1.73	2.35	1.19	3.94
LL38P	-	1"	6.47	1.98	2.67	1.38	4.56
LL48P	-	1-1/4"	7.53	2.42	3.20	1.75	5.31
LL58P	-	1-1/2"	9.13	2.82	4.04	2.13	6.50
LL68P	-	2"	11.00	3.60	5.00	3.00	8.56
LL78P	-	2-1/2"	13.94	4.48	6.73	4.25	10.88
LL88P	-	3"	13.94	4.85	6.73	4.25	10.88

LL MARK 9

Cat.#		TradeSize	A	B	C	D	E
Ferrous	Alum.						
-	LL19P	1/2"	4.63	1.42	2.17	1.19	3.31
-	LL29P	3/4"	5.29	1.67	2.42	1.38	3.94
-	LL39P	1"	6.13	1.92	2.67	1.50	4.56
-	LL49P	1-1/4"	7.07	2.54	3.13	1.94	5.31
-	LL59P	1-1/2"	7.79	2.79	3.48	2.25	6.00
-	LL69P	2"	10.07	3.48	4.17	2.88	8.06
-	LL79P	2-1/2"	13.98	4.48	6.73	4.25	10.88
-	LL89P	3"	13.98	4.85	6.73	4.25	10.88
-	LL99P	3-1/2"	16.92	5.73	8.17	5.44	13.44
-	LL109P	4"	16.92	5.98	8.17	5.44	13.44

LR MARK 9

Cat.#		TradeSize	A	B	C	D	E
Ferrous	Alum.						
-	LR19P	1/2"	4.63	1.42	2.17	1.19	3.31
-	LR29P	3/4"	5.29	1.67	2.42	1.38	3.94
-	LR39P	1"	6.13	1.92	2.67	1.50	4.56
-	LR49P	1-1/4"	7.07	2.54	3.13	1.94	5.31
-	LR59P	1-1/2"	7.79	2.79	3.48	2.25	6.00
-	LR69P	2"	10.07	3.48	4.17	2.88	8.06
-	LR79P	2-1/2"	13.98	4.48	6.73	4.25	10.88
-	LR89P	3"	13.98	4.85	6.73	4.25	10.88
-	LR99P	3-1/2"	16.92	5.73	8.17	5.44	13.44
-	LR109P	4"	16.92	5.98	8.17	5.44	13.44

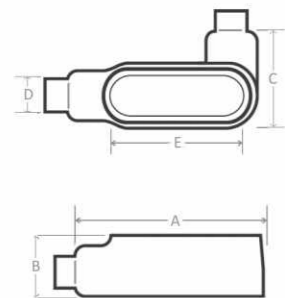
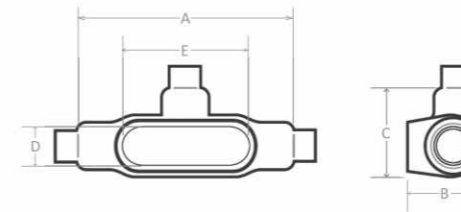

LR FORM 7

Cat.#		TradeSize	A	B	C	D	E
Ferrous	Alum.						
LR17P	LR17AP	1/2"	4.60	1.42	2.29	0.94	3.19
LR27P	LR27AP	3/4"	5.23	1.67	2.48	1.13	3.81
LR37P	LR37AP	1"	6.04	1.92	2.79	1.38	4.50
LR47P	LR47AP	1-1/4"	6.54	2.35	3.23	1.75	5.00
LR57P	LR57AP	1-1/2"	7.17	2.60	3.60	1.94	5.44
LR67P	LR67AP	2"	8.17	3.17	4.17	2.44	6.38
LR77P	LR77AP	2 1/2"	10.54	3.67	5.79	3.56	8.38
LR87P	LR87AP	3"	10.54	4.42	5.79	3.56	8.38
LR97P	LR97AP	3 1/2"	12.73	4.92	6.98	4.50	10.25
LR107P	LR107AP	4"	12.73	5.42	6.98	4.50	10.25

T FORM 7

Cat.#		TradeSize	A	B	C	D	E
Ferrous	Alum.						
T17P	T17AP	1/2"	5.60	1.80	2.35	0.95	3.20
T27P	T27AP	3/4"	6.25	2.04	2.67	1.13	3.81
T37P	T37AP	1"	7.25	2.29	3.04	1.38	4.50
T47P	T47AP	1-1/4"	7.44	2.35	3.23	1.75	5.00
T57P	T57AP	1-1/2"	8.19	2.60	3.60	1.94	5.44
T67P	T67AP	2"	9.19	3.17	4.16	2.44	6.38
T77P	T77AP	2 1/2"	12.00	3.67	5.79	3.56	8.38
T87P	T87AP	3"	12.06	4.42	5.79	3.56	8.38
T97P	T97AP	3 1/2"	14.31	4.92	6.98	4.50	10.25
T107P	T107AP	4"	14.31	5.42	6.98	4.50	10.25

LR FORM 8

Cat.#		TradeSize	A	B	C	D	E
Ferrous	Alum.						
LR18P	-	1/2"	4.94	1.48	2.20	1.00	3.31
LR28P	-	3/4"	5.56	1.73	2.35	1.19	3.94
LR38P	-	1"	6.47	1.98	2.67	1.38	4.56
LR48P	-	1-1/4"	7.53	2.42	3.20	1.75	5.31
LR58P	-	1-1/2"	9.13	2.82	4.04	2.13	6.50
LR68P	-	2"	11.00	3.60	5.04	3.00	8.56
LR78P	-	2-1/2"	13.94	4.48	6.73	4.25	10.88
LR88P	-	3"	13.94	4.85	6.73	4.25	10.88

T FORM 8

Cat.#		TradeSize	A	B	C	D	E
Ferrous	Alum.						
T18P	-	1/2"	5.69	1.79	2.16	1.00	3.31
T28P	-	3/4"	6.28	2.04	2.31	1.19	3.94
T38P	-	1"	7.31	2.29	2.63	1.38	4.56
T48P	-	1-1/4"	8.50	2.67	3.16	1.75	5.31
T58P	-	1-1/2"	10.38	2.82	4.00	2.13	6.50
T68P	-	2"	12.25	3.60	5.00	3.00	8.56
T78P	-	2-1/2"	15.63	4.48	6.69	4.25	10.88
T88P	-	3"	15.63	4.85	6.69	4.25	10.88

T MARK 9

Cat.#		TradeSize	A	B	C	D	E
Ferrous	Alum.						
T19P	-	1/2"	5.00	1.38	2.17	1.19	3.31
T29P	-	3/4"	5.69	1.88	2.42	1.38	3.31
T39P	-	1"	6.59	1.88	2.67	1.50	4.56
T49P	-	1-1/4"	7.50	2.50	3.13	1.94	5.31
T59P	-	1-1/2"	8.25	2.75	3.48	2.25	6.00
T69P	-	2"	10.50	3.44	4.17	2.88	8.06
T79P	-	2-1/2"	15.63	4.44	6.73	4.25	10.88
T89P	-	3"	15.63	4.81	6.73	4.25	10.88
T99P	-	3-1/2"	18.75	5.69	8.17	5.44	13.44
T109P	-	4"	18.75	5.94	8.17	5.44	13.44

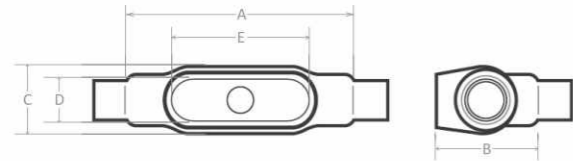
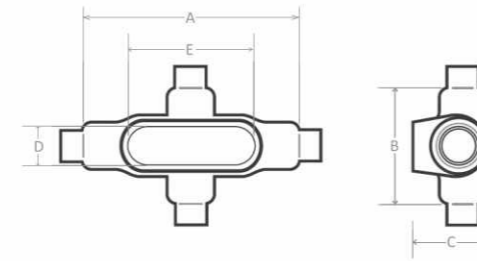

TB FORM 7

Cat.#		TradeSize	A	B	C	D	E
Ferrous	Alum.						
TB17P	TB17AP	1/2"	5.63	2.63	1.64	0.94	3.19
TB27P	TB27AP	3/4"	6.25	2.88	1.83	1.13	3.81
TB37P	TB37AP	1"	7.25	3.25	2.08	1.38	4.50
TB47P	TB47AP	1-1/4"	8.06	3.31	2.27	1.75	5.00
TB57P	TB57AP	1-1/2"	8.19	5.00	2.52	1.94	5.44
TB67P	TB67AP	2"	9.19	6.13	3.08	2.44	6.38

TB FORM 8

Cat.#		TradeSize	A	B	C	D	E
Ferrous	Alum.						
TB18P	-	1/2"	5.69	2.53	1.46	1.00	3.31
TB28P	-	3/4"	6.28	2.75	1.64	1.19	3.94
TB38P	-	1"	7.31	3.13	1.83	1.38	4.56
TB48P	-	1-1/4"	8.50	3.34	2.27	1.75	5.31
TB58P	-	1-1/2"	10.38	4.03	2.83	2.13	6.50
TB68P	-	2"	12.25	4.81	3.83	3.00	8.56

TB MARK 9

Cat.#		TradeSize	A	B	C	D	E
Ferrous	Alum.						
-	TB19P	1/2"	5.00	2.13	1.46	1.19	3.31
-	TB29P	3/4"	5.69	2.41	1.64	1.38	3.31
-	TB39P	1"	6.59	2.84	1.83	1.50	4.56
-	TB49P	1-1/4"	7.50	3.47	2.27	1.94	5.88
-	TB59P	1-1/2"	8.34	3.88	2.58	2.25	6.00
-	TB69P	2"	10.63	4.59	3.30	2.81	8.01

X FORM 7

Cat.#		TradeSize	A	B	C	D	E
Ferrous	Alum.						
X17P	X17AP	1/2"	5.63	3.31	1.79	0.94	3.19
X27P	X27AP	3/4"	6.25	3.50	2.04	1.13	3.81
X37P	X37AP	1"	7.25	4.00	2.29	1.38	4.50
X47P	X47AP	1-1/4"	8.06	4.13	2.35	1.75	5.00
X57P	X57AP	1-1/2"	8.19	4.63	2.60	1.94	5.44
X67P	X67AP	2"	9.19	5.19	3.17	2.44	6.38

X FORM 8

Cat.#		TradeSize	A	B	C	D	E
Ferrous	Alum.						
X18P	-	1/2"	5.69	2.91	1.79	1.00	3.31
X28P	-	3/4"	6.28	3.06	2.04	1.19	3.94
X38P	-	1"	7.31	3.50	2.29	1.38	4.56
X48P	-	1-1/4"	8.50	4.13	2.67	1.75	5.31
X58P	-	1-1/2"	10.38	5.25	3.51	2.13	6.50
X68P	-	2"	12.25	6.25	3.60	3.00	8.56

X MARK 9

Cat.#		TradeSize	A	B	C	D	E
Ferrous	Alum.						
X19P	-	1/2"	5.69	2.91	1.79	1.00	3.31
X29P	-	3/4"	6.28	3.06	2.04	1.19	3.31
X39P	-	1"	7.31	3.50	2.29	1.38	4.56

COVER

STYLE	Size and Description									
	1/2"	1"	1 1/4"	1 1/2"	2"	2 1/2"	3"	3 1/2"	4"	
FORM 7	170FP	270FP	370FP	470FP	570FP	670FP	770FP	870FP	970FP	1070FP
FORM 8	180FP	280FP	380FP	480FP	580FP	680FP	780FP	880FP	980FP	1080FP
MARK 9	180FP	280FP	380FP	480FP	580FP	680FP	780FP	880FP	980FP	1080FP
FORM 7 ALUM.	170SAP	270SAP	370SAP	470SAP	570SAP	670SAP	770SAP	870SAP	970SAP	1070SAP

PVC COATED FS AND FD SERIES BOX

2 mil grey urethane coating on interior and threads
 40 mil PVC coating bonded to exterior
 10 trade sizes from 1/2" through 4"
 Sealing sleeves on all conduit openings
 Internal grounding screw is standard



Single Gang Box

Size and Description					
TradeSize	STYLE	DEAD END	FEED-THRU	HUB RIGHT	HUB LEFT
1/2"	Shallow	FS1	FSC1	FSR1	FSL1
3/4"	Shallow	FS2	FSC2	FSR2	FSL2
1"	Shallow	FS3	FSC3	-	-
1/2"	Deep	FD1	FDC1	FDR1	FDL1
3/4"	Deep	FD2	FDC2	FDR2	FDL2
1"	Deep	FD3	FDC3	-	-
3/4"	Shallow	-	FSCC2	-	-
3/4"	Deep	-	FDC2	-	-
3/4"	Shallow	FSS2	-	-	-
3/4"	Deep	FDD2	-	-	-

Double Gang Box

Size and Description					
TradeSize	STYLE	DEAD END	FEED-THRU	HUB RIGHT	HUB LEFT
3/4"	Shallow	FS22	-	-	-
3/4"	Deep	FD22	-	-	-
3/4"	Shallow	FSS222	-	-	-
3/4"	Deep	FDS222	-	-	-
3/4"	Shallow	-	FSC222	-	-
3/4"	Deep	-	FDC222	-	-

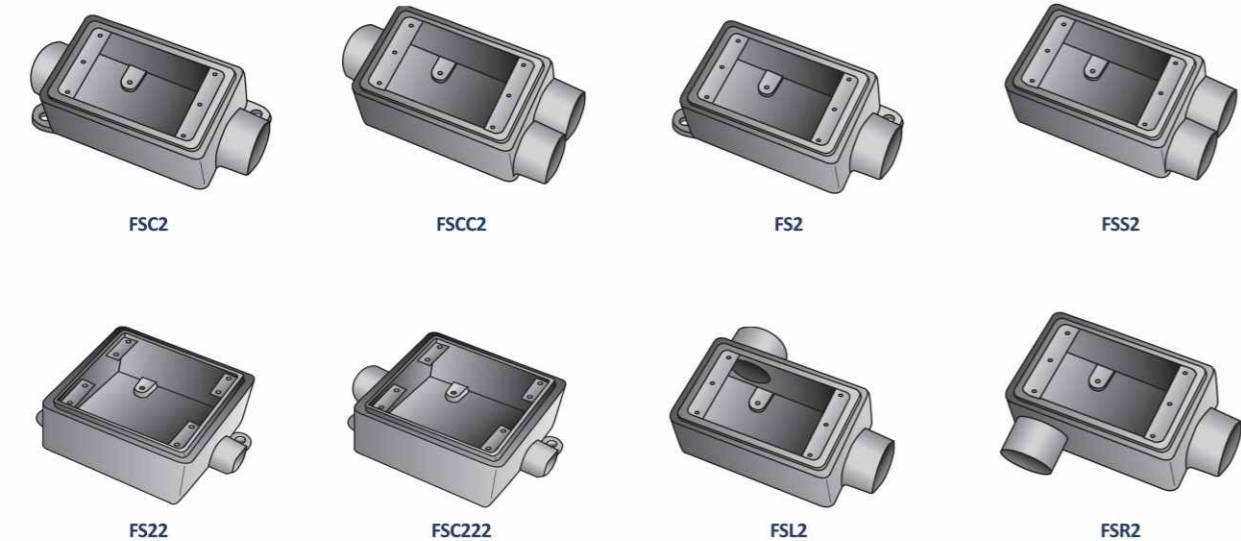

Single Gang Cover

Cat. #	Description	Material
DS23	Duplex Receptacle Cover	Steel
DS21G	Round Flush Receptacle Cover	Iron
DS32G	Toggle Switch Cover	Iron
DS100G	Blank Cover	Alum.
CWPDR-FS	Duplex Receptacle Cover-Box Mount-Horizontal	Alum.
CFSDR	Duplex Receptacle Cover-Box Mount-Vertical	Alum.
CFSHG	GFCI Receptacle Cover-Box Mount-Horizontal	Alum.
CFSRG	GFCI Receptacle Cover-Box Mount-Vertical	Alum.
CFSTF	Front Lever Switch Cover-Box Mount-NEMA 4	Alum.

Double Gang Cover

Cat. #	Description	Material
S1002G	Blank Cover	Iron
S322G	2 Toggle Switch Cover	Iron
S232	2 Duplex Receptacle Cover	Stamped Steel
S232GFI	2 GFCI Receptacle Cover	Steel
2CFST	2 Plunger Style Switch Cover	Alum.



PVC COATED LIQUID TIGHT CONNECTOR

2 mil grey urethane coating on interior
 40 mil PVC coating bonded to exterior
 Sealing sleeves on all conduit openings
 Available in straight, 45° or 90°
 Available with an external grounding lug



LT STRAIGHT CONNECTOR

Cat.#		Trade Size	A	B	C
Ferrous	Alum.				
LTC0010P	LTC0010AP	3/8"	1.24	1.50	0.56
LTC0015P	LTC0015AP	1/2"	1.46	1.56	0.56
LTC0020P	LTC0020AP	3/4"	1.74	1.63	0.56
LTC0025P	LTC0025AP	1"	1.96	2.06	0.75
LTC0032P	LTC0032AP	1-1/4"	2.36	2.50	0.81
LTC0040P	LTC0040AP	1-1/2"	2.80	2.69	0.81
LTC0050P	LTC0050AP	2"	3.33	3.06	0.88
LTC0065P	LTC0065AP	2-1/2"	3.83	4.13	1.00
LTC0080P	LTC0080AP	3"	4.58	4.25	1.00
LTC00100P	LTC00100AP	4"	5.58	4.50	1.13



LT 45° CONNECTOR

Cat.#		Trade Size	A	B	C
Ferrous	Alum.				
LTC4510P	LTC4510AP	3/8"	1.24	1.56	0.56
LTC4515P	LTC4515AP	1/2"	1.46	1.88	0.56
LTC4520P	LTC4520AP	3/4"	1.74	2.13	0.56
LTC4525P	LTC4525AP	1"	1.96	1.25	0.75
LTC4532P	LTC4532AP	1-1/4"	2.36	2.75	0.81
LTC4540P	LTC4540AP	1-1/2"	2.80	3.38	0.81
LTC4550P	LTC4550AP	2"	3.33	3.88	0.88
LTC4565P	LTC4565AP	2-1/2"	3.83	4.25	1.00
LTC4580P	LTC4580AP	3"	4.58	4.25	1.00
LTC45100P	LTC45100AP	4"	5.58	4.63	1.13

LT 90° CONNECTOR

Cat.#		Trade Size	A	B	C
Ferrous	Alum.				
LTC9010P	LTC9010AP	3/8"	1.24	1.38	0.56
LTC9015P	LTC9015AP	1/2"	1.46	1.56	0.56
LTC9020P	LTC9020AP	3/4"	1.74	1.75	0.56
LTC9025P	LTC9025AP	1"	1.96	2.19	0.75
LTC9032P	LTC9032AP	1-1/4"	2.36	2.75	0.81
LTC9040P	LTC9040AP	1-1/2"	2.80	2.94	0.81
LTC9050P	LTC9050AP	2"	3.33	3.44	0.88
LTC9065P	LTC9065AP	2-1/2"	3.83	8.88	1.00
LTC9080P	LTC9080AP	3"	4.58	10.25	1.00
LTC90100P	LTC90100AP	4"	5.58	12.63	1.13

LT GROUNDED STRAIGHT CONNECTOR

Cat.#		Trade Size	A	B	C
Ferrous	Alum.				
LTGC0010P	LTGC0010AP	3/8"	1.24	1.50	0.56
LTGC0015P	LTGC0015AP	1/2"	1.46	1.56	0.56
LTGC0020P	LTGC0020AP	3/4"	1.74	1.63	0.56
LTGC0025P	LTGC0025AP	1"	1.96	2.06	0.75
LTGC0032P	LTGC0032AP	1-1/4"	2.33	2.50	0.81
LTGC0040P	LTGC0040AP	1-1/2"	3.33	2.69	0.81
LTGC0050P	LTGC0050AP	2"	3.89	3.06	0.88
LTGC0065P	LTGC0065AP	2-1/2"	4.52	4.13	1.00
LTGC0080P	LTGC0080AP	3"	5.27	4.25	1.00
LTGC00100P	LTGC00100AP	4"	6.21	4.50	1.13



LT GROUNDED 45° CONNECTOR

Cat.#		Trade Size	A	B	C
Ferrous	Alum.				
LTGC4510P	LTGC4510AP	3/8"	1.24	1.56	0.56
LTGC4515P	LTGC4515AP	1/2"	1.46	1.88	0.56
LTGC4520P	LTGC4520AP	3/4"	1.74	2.13	0.56
LTGC4525P	LTGC4525AP	1"	1.96	1.25	0.75
LTGC4532P	LTGC4532AP	1-1/4"	3.33	2.75	0.81
LTGC4540P	LTGC4540AP	1-1/2"	3.33	3.38	0.81
LTGC4550P	LTGC4550AP	2"	3.89	3.88	0.88
LTGC4565P	LTGC4565AP	2-1/2"	4.52	4.25	1.00
LTGC4580P	LTGC4580AP	3"	5.27	4.25	1.00
LTGC45100P	LTGC45100AP	4"	6.21	4.63	1.13

LT GROUNDED 90° CONNECTOR

Cat.#		Trade Size	A	B	C
Ferrous	Alum.				
LTGC9010P	LTGC9010AP	3/8"	1.24	1.38	0.56
LTGC9015P	LTGC9015AP	1/2"	1.46	1.56	0.56
LTGC9020P	LTGC9020AP	3/4"	1.74	1.75	0.56
LTGC9025P	LTGC9025AP	1"	1.96	2.19	0.75
LTGC9032P	LTGC9032AP	1-1/4"	2.33	2.75	0.81
LTGC9040P	LTGC9040AP	1-1/2"	3.33	2.94	0.81
LTGC9050P	LTGC9050AP	2"	3.89	3.44	0.88
LTGC9065P	LTGC9065AP	2-1/2"	4.52	8.88	1.00
LTGC9080P	LTGC9080AP	3"	5.27	10.25	1.00
LTGC90100P	LTGC90100AP	4"	6.21	12.63	1.13

PVC COATED CONDUIT EXPANSION JOINT

2 mil grey urethane coating on interior
 40 mil PVC coating bonded to exterior
 Sealing sleeves on all conduit openings
 Available with either 4" or 8" maximum movement
 Internally Grounded

4" TRAVEL XJG SERIES

Cat.#	Trade Size	A DIA.	B LENGTH
XJG415P	1/2"	1.83	6.75
XJG420P	3/4"	2.20	6.75
XJG425P	1"	2.51	7.25
XJG432P	1-1/4"	3.27	7.56
XJG440P	1-1/2"	3.76	7.87
XJG450P	2"	4.83	8.25
XJG465P	2-1/2"	4.95	9.31
XJG480P	3"	5.45	10.00
XJG490P	3-1/2"	6.70	9.81
XJG4100P	4"	6.70	9.81

8" TRAVEL XJG SERIES

Cat.#	Trade Size	A DIA.	B LENGTH
XJG415P	1/2"	1.83	10.75
XJG420P	3/4"	2.20	10.75
XJG425P	1"	2.51	11.25
XJG432P	1-1/4"	3.27	11.56
XJG440P	1-1/2"	3.76	11.87
XJG450P	2"	4.83	12.25
XJG465P	2-1/2"	4.95	13.31
XJG480P	3"	5.45	14.00
XJG490P	3-1/2"	6.70	13.81
XJG4100P	4"	6.70	13.81

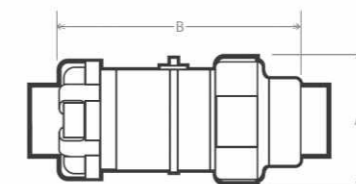

PVC COATED CONDUIT AND GROUNDING BUSHING

2 mil grey urethane coating on interior and threads
 40 mil PVC coating bonded to exterior
 Aluminum lug for copper or aluminum grounding conductor



CONDUIT BUSHING

Cat.#		
	GROUNDING	Trade Size
RBU15MP	RGB15MP	1/2"
RBU20MP	RGB20MP	3/4"
RBU25MP	RGB25MP	1"
RBU32MP	RGB32MP	1-1/4"
RBU40MP	RGB40MP	1-1/2"
RBU50MP	RGB50MP	2"
RBU65MP	RGB65MP	2-1/2"
RBU80MP	RGB80MP	3"
RBU90MP	RGB90MP	3-1/2"
RBU100MP	RGB100MP	4"
RBU125MP	RGB125MP	5"
RBU150MP	RGB150MP	6"

PVC COATED SPLIT COUPLING

2 mil grey urethane coating on interior and threads
 40 mil PVC coating bonded to exterior
 Sealing sleeves on all conduit openings



SPLIT COUPLING

Cat.#	Trade Size
SPC15P	1/2"
SPC20P	3/4"
SPC25P	1"
SPC32P	1-1/4"
SPC40P	1-1/2"
SPC50P	2"
SPC65P	2-1/2"
SPC80P	3"
SPC90P	3-1/2"
SPC100P	4"
SPC125P	5"
SPC150P	6"

PVC COATED REDUCING BUSHING

2 mil grey urethane coating

Cat.#	Trade Size
RRB2015P	3/4--1/2
RRB2515P	1--1/2
RRB2520P	1--3/4
RRB3215P	1 1/4--1/2
RRB3220P	1 1/4--3/4
RRB3225P	1 1/4--1
RRB4015P	1 1/2--1/2
RRB4020P	1 1/2--3/4
RRB4025P	1 1/2--1
RRB4032P	1 1/2--1 1/4
RRB5015P	2--1/2
RRB5020P	2--3/4
RRB5025P	2--1
RRB5032P	2--1 1/4
RRB5040P	2--1/2



PVC COATED LOCKNUT

2 mil grey urethane coating

Cat.#	Trade Size
RLN15P	1/2"
RLN20P	3/4"
RLN25P	1"
RLN32P	1 1/4"
RLN40P	1 1/2"
RLN50P	2"
RLN65P	2 1/2"
RLN80P	3"
RLN90P	3 1/2"
RLN100P	4"
RLN125P	5"
RLN150P	6"





PVC COATED
HAZARDOUS
LOCATION PRODUCTS



PVC COATED GUA SERIES OUTLET BOX

2 mil grey urethane coating on interior
 40 mil PVC coating bonded to exterior styles and configurations
 Sealing sleeves on all conduit openings
 Neoprene O-ring is standard
 Cast iron alloy bodies and cast aluminum covers(iron covers also available)
 Internal green grounding screw is standard
 NEC/CEC:
 Class I, Division 1 & 2, Groups C, D
 Class II, Division 1, Groups E, F, G
 Class II, Division 2, Groups F, G
 Class III

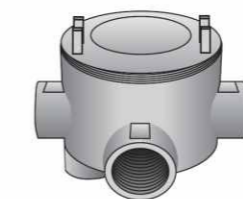
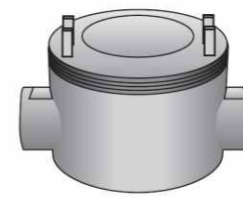
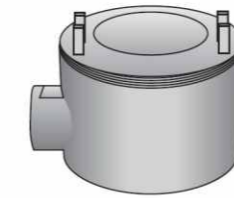

GUA

Cat.#		Trade Size	COVER OPENING
Ferrous	Alum.		
GUA14P	GUA14AP	1/2"	2"
GUA24P	GUA24AP	3/4"	2"
GUA16P	GUA16AP	1/2"	3"
GUA26P	GUA26AP	3/4"	3"
GUA36P	GUA36AP	1"	3"
GUA47P	GUA47AP	1-1/4"	3-5/8"
GUA59P	GUA59AP	1-1/2"	5"

GUAB

Cat.#		Trade Size	COVER OPENING
Alum.			
GUAB14P	GUAB14AP	1/2"	2"
GUAB24P	GUAB16AP	1/2"	3"
GUAB16P	GUAB24AP	3/4"	2"
GUAB26P	GUAB26AP	3/4"	3"
GUAB36P	GUAB36AP	1"	3"
GUAB47P	GUAB47AP	1-1/4"	3-5/8"
GUAB59P	GUAB59AP	1-1/2"	5"
GUAB69P	GUAB69AP	2"	5"

GUAC

Cat.#		Trade Size	COVER OPENING
Ferrous	Alum.		
GUAC14P	GUAC14AP	1/2"	2"
GUAC16P	GUAC16AP	1/2"	3"
GUAC24P	GUAC24AP	3/4"	2"
GUAC26P	GUAC26AP	3/4"	3"
GUAC36P	GUAC36AP	1"	3"
GUAC47P	GUAC47AP	1-1/4"	3-5/8"
GUAC49P	GUAC49AP	1-1/4"	5"
GUAC59P	GUAC59AP	1-1/2"	5"
GUAC69P	GUAC69AP	2"	5"

GUAW

Cat.#		Trade Size	COVER OPENING
Ferrous	Alum.		
GUAW14P	GUAW14AP	1/2"	2"
GUAW16P	GUAW16AP	1/2"	3"
GUAW24P	GUAW24AP	3/4"	2"
GUAW26P	GUAW26AP	3/4"	3"

GUAL

Cat.#		Trade Size	COVER OPENING
Ferrous	Alum.		
GUAL14P	GUAL14AP	1/2"	2"
GUAL16P	GUAL16AP	1/2"	3"
GUAL24P	GUAL24AP	3/4"	2"
GUAL26P	GUAL26AP	3/4"	3"
GUAL36P	GUAL36AP	1"	3"
GUAL47P	GUAL47AP	1-1/4"	3-5/8"
GUAL49P	GUAL49AP	1-1/4"	5"
GUAL59P	GUAL59AP	1-1/2"	5"
GUAL69P	GUAL69AP	2"	5"



GUAN

Cat.#		Trade Size	COVER OPENING
Ferrous	Alum.		
GUAN14P	GUAN14AP	1/2"	2"
GUAN16P	GUAN16AP	1/2"	3"
GUAN24P	GUAN24AP	3/4"	2"
GUAN26P	GUAN26AP	3/4"	3"
GUAN36P	GUAN36AP	1"	3"
GUAN47P	GUAN47AP	1-1/4"	3-5/8"
GUAN59P	GUAN59AP	1-1/2"	5"
GUAN69P	GUAN69AP	2"	5"



GUAT

Cat.#		Trade Size	COVER OPENING
Ferrous	Alum.		
GUAT15P	GUAT15AP	1/2"	2"
GUAT16P	GUAT16AP	1/2"	3"
GUAT24P	GUAT24AP	3/4"	2"
GUAT26P	GUAT26AP	3/4"	3"
GUAT36P	GUAT36AP	1"	3"
GUAT47P	GUAT47AP	1-1/4"	3-5/8"
GUAT59P	GUAT59AP	1-1/2"	5"
GUAT69P	GUAT69AP	2"	5"

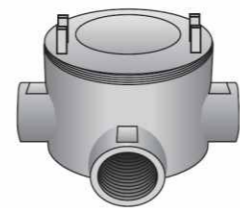

GUAX

Cat.#		Trade Size	COVER OPENING
Ferrous	Alum.		
GUAX14P	GUAX14AP	1/2"	2"
GUAX16P	GUAX16AP	1/2"	3"
GUAX24P	GUAX24AP	3/4"	2"
GUAX26P	GUAX26AP	3/4"	3"
GUAX36P	GUAX36AP	1"	3"
GUAX47P	GUAX47AP	1-1/4"	3-5/8"
GUAX59P	GUAX59AP	1-1/2"	5"
GUAX69P	GUAX69AP	2"	5"



PVC COATED CONDUIT UNOIN

2 mil grey urethane coating on interior
 40 mil PVC coating bonded to exterior
 Sealing sleeves on all conduit openings
 NEC/CEC:
 Class I, Division 1 & 2, Groups A, B, C, D
 Class II, Division 1, Groups E, F, G
 Class III, Division 1 & 2



UNY

Cat.#		Trade Size	Length	Dia
Ferrous	Alum.			
UNY15P	UNY15AP	1/2"	2.39	1.50
UNY20P	UNY20AP	3/4"	2.44	1.81
UNY25P	UNY25AP	1"	2.75	2.00
UNY32P	UNY32AP	1-1/4"	3.06	2.75
UNY40P	UNY40AP	1-1/2"	3.63	3.06
UNY50P	UNY50AP	2"	3.50	3.81
UNY65P	UNY65AP	2-1/2"	4.81	4.31
UNY80P	UNY80AP	3"	5.34	5.06
UNY90P	UNY90AP	3-1/2"	5.50	5.69
UNY100P	UNY100AP	4"	5.63	6.19
UNY125P	UNY125AP	5"	5.25	8.19
UNY150P	UNY150AP	6"	5.38	9.31



UNF

Cat.#		Trade Size	Length	Dia
Ferrous	Alum.			
UNF15P	UNF15AP	1/2"	1.88	1.50
UNF20P	UNF20AP	3/4"	2.13	1.81
UNF25P	UNF25AP	1"	2.16	2.00
UNF32P	UNF32AP	1-1/4"	2.25	2.75
UNF40P	UNF40AP	1-1/2"	2.75	3.06
UNF50P	UNF50AP	2"	2.50	3.81
UNF65P	UNF65AP	2-1/2"	3.50	4.31
UNF80P	UNF80AP	3"	4.00	5.06
UNF90P	UNF90AP	3-1/2"	4.16	5.69
UNF100P	UNF100AP	4"	4.25	6.19
UNF125P	UNF125AP	5"	3.81	8.19
UNF150P	UNF150AP	6"	3.81	9.31



PVC COATED SEALING FITTING

2 mil grey urethane coating on interior
 40 mil PVC coating bonded to exterior
 Sealing sleeves on all conduit openings
 NEC/CEC:
 Class I, Division 1 & 2, Groups C, D
 Class II, Division 1, Groups E, F, G
 Class III, Division 1 & 2

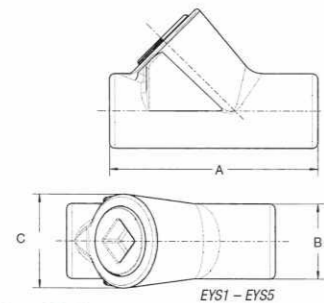

EYD SERIES DRAIN SEALING FITTING

Cat.#		Trade Size	DIMENSION		TURNING RADIUS
FEMALE	MALE& FEMALE		A	B	
EYD1P	EYD16P	1/2"	3.81	1.50	1.75
EYD2P	EYD26P	3/4"	4.08	1.75	1.98
EYD3P	EYD36P	1"	4.85	2.19	2.19
EYD4P	EYD46P	1-1/4"	5.00	2.25	1.80
EYD5P	EYD56P	1-1/2"	5.44	2.44	2.00
EYD6P	EYD66P	2"	6.25	3.00	2.32
EYD7P	EYD76P	2-1/2"	7.50	3.50	2.69
EYD8P	EYD86P	3"	8.50	4.25	3.15
EYD9P	EYD96P	3-1/2"	9.19	4.75	3.38
EYD10P	EYD106P	4"	9.75	5.25	3.64

EYS SERIES SEALING FITTING

Cat.#		Trade Size	DIMENSION		TURNING RADIUS
FEMALE	MALE& FEMALE		A	B	
EYS1P	EYS16P	1/2"	3.31	1.25	1.66
EYS2P	EYS26P	3/4"	3.65	1.50	1.96
EYS3P	EYS36P	1"	4.25	1.75	2.40
EYS3P	EYS36P	1"			
EYS11P	EYS116P	1/2"	3.63	1.25	1.09
EYS21P	EYS216P	3/4"	3.66	1.50	1.25
EYS31P	EYS316P	1"	4.25	1.75	1.59
EYS4P	EYS46P	1-1/4"	5.00	2.25	1.81
EYS5P	EYS56P	1-1/2"	5.44	2.44	2.00
EYS6P	EYS66P	2"	6.25	3.00	2.31
EYS7P	EYS76P	2-1/2"	7.50	3.50	2.56
EYS8P	EYS86P	3"	8.50	4.25	3.09
EYS9P	EYS96P	3-1/2"	9.19	4.75	3.38
EYS10P	EYS106P	4"	9.75	5.25	3.53

EZS SERIES SEALING FITTING

Cat.#		Trade Size	DIMENSION		TURNING RADIUS
FEMALE	MALE& FEMALE		A	B	
EZS1P	EZS16P	1/2"	4.31	3.71	1.88
EZS2P	EZS26P	3/4"	4.31	3.71	1.88
EZS3P	EZS36P	1"	4.93	4.05	2.13
EZS4P	EZS46P	1-1/4"	5.06	4.49	2.31
EZS5P	EZS56P	1-1/2"	5.31	4.64	2.34
EZS6P	EZS66P	2"	7.06	5.49	3.28
EZS7P	EZS76P	2-1/2"	7.93	5.92	3.38
EZS8P	EZS86P	3"	5.63	6.58	3.88

EZD SERIES SEALING FITTING

Cat.#	Trade Size	DIMENSION		TURNING RADIUS
		A	B	
EZS1P	1/2"	4.19	3.08	2.06
EZS2P	3/4"	4.19	3.08	2.19
EZS3P	1"	4.94	3.58	2.44
EZS4P	1-1/4"	4.94	3.58	2.63
EZS5P	1-1/2"	5.19	3.58	2.69
EZS6P	2"	7.13	5.64	3.69

PVC COATED KNOCKOUT HUB

2 mil grey urethane coating on interior
 40 mil PVC coating bonded to exterior
 Sealing sleeves on conduit side of hub
 O-ring gasket provides additional seal
 NEC/CEC:
 Class I, Division 2
 Class II, Division 1 & 2
 Class III, Division 1 & 2

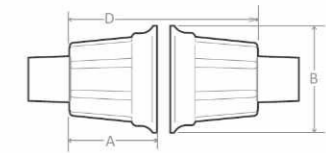
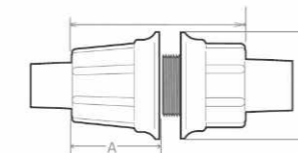
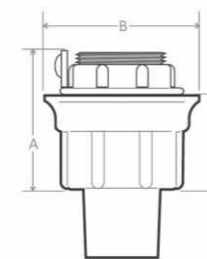
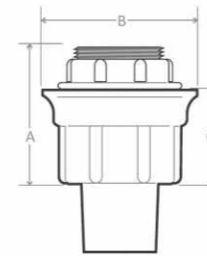

ST

Cat.#		Trade Size	A	B	C
Zinc	Alum.				
ST15P	ST15AP	1/2"	1.34	2.00	0.81
ST20P	ST20AP	3/4"	1.47	2.25	0.91
ST25P	ST25AP	1"	1.66	2.50	1.03
ST32P	ST32AP	1-1/4"	1.69	3.25	1.03
ST40P	ST40AP	1-1/2"	1.69	3.50	1.03
ST50P	ST50AP	2"	1.75	4.25	1.09
ST65P	ST65AP	2-1/2"	2.22	4.75	1.28
ST80P	ST80AP	3"	2.31	5.25	1.38
ST90P	ST90AP	3-1/2"	2.38	5.50	1.44
ST100P	ST100AP	4"	2.44	6.25	1.50
ST125P	ST125AP	5"	2.94	7.50	2.00
ST150P	ST150AP	6"	3.00	8.50	2.00

STG

Cat.#		Trade Size	A	B	C
Zinc	Alum.				
STG15P	STG15AP	1/2"	1.34	2.00	0.81
STG20P	STG20AP	3/4"	1.47	2.25	0.91
STG25P	STG25AP	1"	1.66	2.50	1.03
STG32P	STG32AP	1-1/4"	1.69	3.25	1.03
STG40P	STG40AP	1-1/2"	1.69	3.50	1.03
STG50P	STG50AP	2"	1.75	4.25	1.09
STG65P	STG65AP	2-1/2"	2.22	4.75	1.28
STG80P	STG80AP	3"	2.31	5.25	1.38
STG90P	STG90AP	3-1/2"	2.38	5.50	1.44
STG100P	STG100AP	4"	2.44	6.25	1.50
STG125P	STG125AP	5"	2.94	7.50	2.00
STG150P	STG150AP	6"	3.00	8.50	2.00

STTB

Cat.#		Trade Size	A	B
Zinc	Alum.			
STTB15P	STTB15AP	1/2"	1.34	2.00
STTB20P	STTB20AP	3/4"	1.47	2.25
STTB25P	STTB25AP	1"	1.66	2.50
STTB32P	STTB32AP	1-1/4"	1.69	3.25
STTB40P	STTB40AP	1-1/2"	1.69	3.50
STTB50P	STTB50AP	2"	1.75	4.25
STTB65P	STTB65AP	2-1/2"	2.22	4.75
STTB80P	STTB80AP	3"	2.31	5.25
STTB90P	STTB90AP	3-1/2"	2.38	5.50
STTB100P	STTB100AP	4"	2.44	6.25

STTTB

Cat.#		Trade Size	A	B
Zinc	Alum.			
STTTB15P	STTTB15AP	1/2"	1.34	2.00
STTTB20P	STTTB20AP	3/4"	1.47	2.25
STTTB25P	STTTB25AP	1"	1.66	2.50
STTTB32P	STTTB32AP	1-1/4"	1.69	3.25
STTTB40P	STTTB40AP	1-1/2"	1.69	3.50
STTTB50P	STTTB50AP	2"	1.75	4.25

PVC COATED TECK SERIES CABLE FITTING

40 mil PVC coating bonded to exterior
 Material is aluminum
 Stainless steel copper-plated spring provides
 Watertight seal on outer sheath of cable
 Standard neoprene seal suitable for use in
 operating temperatures -25? to 60?C
 An integral o-ring seal on entry threads
 NEC/CEC:
 Class I, Division 1, Groups A, B, C, D
 Class II, Division 1, Groups E, F, G

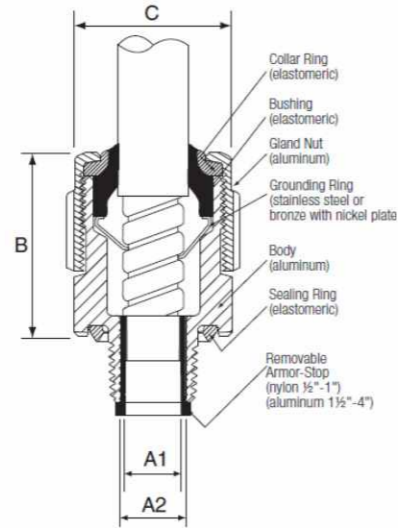

STE SERIES FITTING

Cat.#	Trade Size	STRIP LENGTH	GLAND TORQUE	RANGE OVER JACKET		RANGE OVER ARMOR		A1:THROAT DIA.MIN W/END STOP	A2:THROAT DIA.MIN W/END STOP	B OVERALL HEIGHT	C MAX. WIDTH
				MIN.	MAX.	MIN.	MAX.				
STE50P	1/2"	1.25	300	0.60	0.99	0.52	0.90	0.51	0.61	2.65	1.63
STE75P	3/4"	1.25	600	0.86	1.21	0.78	1.13	0.66	0.82	2.90	2.08
STE100P	1"	1.25	700	0.95	1.38	0.87	1.30	0.79	1.04	3.02	2.30
STE125P	1-1/4"	1.25	1000	1.15	1.63	0.99	1.47	0.97	1.25	4.01	2.82
STE150P	1-1/2"	1.75	1200	1.44	1.97	1.28	1.81	1.26	1.56	4.29	3.25
STE200P	2"	1.75	1600	1.83	2.38	1.67	2.22	1.65	2.00	4.12	3.60
STE250P	2-1/2"	2.50	1600	2.27	2.81	2.11	2.68	2.08	2.42	5.32	4.75
STE300P	3"	2.50	1600	2.67	3.27	2.55	3.15	2.53	2.89	5.40	5.40
STE350P	3-1/2"	2.50	1600	3.22	3.87	3.09	3.64	3.07	3.46	5.36	5.90
STE400P	4"	2.50	1600	3.67	4.34	3.55	4.23	3.53	3.94	5.42	6.40

PVC COATE SERVICE ENTRANCE AND MALLEABLE ELBOW

2 mil grey urethane coating on interior
 40 mil PVC coating bonded to exterior
 Sealing sleeves on all conduit openings
 NEC/CEC
 Class I, Division 1 & 2, Groups C, D
 Class II, Division 1, Groups E, F, G
 Class II, Division 2, Groups F, G
 Class III



LBY SERVICE ENTRANCE ELBOW

Cat.#	Trade Size
LBY15P	1/2"
LBY20P	3/4"
LBY25P	1"
LBY32P	1-1/4"
LBY40P	1-1/2"



MALLEABLE ELBOWS - 90° MALE-MALE

Cat.#	Trade Size
EL195P	1/2"
EL295P	3/4"
EL395P	1"



MALLEABLE ELBOWS - 90° FEMALE-FEMALE

Cat.#	Trade Size
EL19P	1/2"
EL29P	3/4"
EL39P	1"
EL49P	1-1/4"
EL59P	1-1/2"
EL69P	2"
EL79P	2-1/2"



MALLEABLE ELBOWS - 90° MALE-FEMALE

Cat.#	Trade Size
EL196P	1/2"
EL1296P	3/4"
EL396P	1"
EL496P	1-1/4"



PVC COATED SUPPORT PRODUCT

40 mil PVC coating bonded to exterior

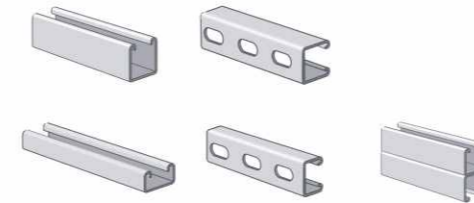

STRUT CHANNEL

Cat.#	STYLE	SIZE	STEEL GAUGE
A12AP	SHALLOW	1-5/8"x3-1/4"	12
A12P	SHALLOW	1-5/8"x1-5/8"	12
A12PP	SLOTTED	1-5/8"x1-5/8"	12
C14P	SHALLOW	1-5/8"x13/16"	12
C14PP	SLOTTED	1-5/8"x13/16"	12

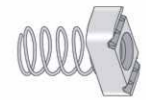

NUT WITH SPRING

Cat.#	SIZE
FNS25P	1/4"
FNS38P	3/8"
FNS50P	1/2"



ROD COUPLING

Cat.#	SIZE
FRC25P	1/4"
FRC38P	3/8"
FRC50P	1/2"



CONTINUOUS THREAD ROD

Cat.#	SIZE
FTR2510	1/4"x10'
FTR3810	3/8"x10'
FTR5010	1/2"x10'



BEAM CLAMP

Cat.#	SIZE	TAPPED HOLE
500P	1"	1/4"-20
501P	1 1/4"	15/16"-18
502P	1 1/2"	3/8"-16
503P	2"	1/2"-13
508P	2 1/2"	1/2"-13

PVC COATED SUPPORT PRODUCTS



ONE HOLE PIPE STRAP

Cat.#	SIZE
RSM15P	1/2"
RSM20P	3/4"
RSM25P	1"
RSM32P	1 1/4"
RSM40P	1 1/2"
RSM50P	2"
RSM65P	2 1/2"
RSM80P	3"
RSM100P	4"

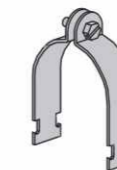

CONDUIT CLAMP

Cat.#	SIZE
CL15P	1/2"
CL20P	3/4"
CL25P	1"
CL32P	1 1/4"
CL40P	1 1/2"
CL50P	2"
CL65P	2 1/2"
CL80P	3"
CL90P	3 1/2"
CL100P	4"
CL125P	5"
CL150P	6"

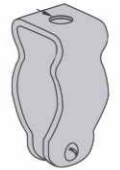

CONDUIT HANGER

Cat.#	SIZE
CLH15P	1/2"
CLH20P	3/4"
CLH25P	1"
CLH32P	1 1/4"
CLH40P	1 1/2"
CLH50P	2"
CLH65P	2 1/2"
CLH80P	3"
CLH90P	3 1/2"
CLH100P	4"
CLH125P	5"
CLH150P	6"

TECHNICAL INFORMATION

URETANE INTERIOR COATING CHEMICAL RESISTANCE



CLAMP BACK SPACER

Cat.#	SIZE
BSC15P	1/2"
BSC20P	3/4"
BSC25P	1"
BSC32P	1 1/4"
BSC40P	1 1/2"
BSC50P	2"
BSC65P	2 1/2"
BSC80P	3"
BSC100P	4"



EDGE CLAMP

Cat.#	SIZE
EDC15P	1/2"
EDC20P	3/4"
EDC25P	1"
EDC32P	1 1/4"
EDC40P	1 1/2"
EDC50P	2"
EDC65P	2 1/2"
EDC80P	3"
EDC100P	4"



TWO HOLES STRAP

Cat.#	SIZE
RSD15P	1/2"
RSD20P	3/4"
RSD25P	1"
RSD32P	1 1/4"
RSD40P	1 1/2"
RSD50P	2"
RSD65P	2 1/2"
RSD80P	3"
RSD100P	4"



RIGHT ANGLE CLAMP

Cat.#	SIZE
RAN15	1/2"
RAN20	3/4"
RAN25	1"
RAN32	1 1/4"
RAN40	1 1/2"
RAN50	2"
RAN65	2 1/2"
RAN80	3"
RAN100	4"



PARALLEL CLAMP

Cat.#	SIZE
PAR15P	1/2"
PAR20P	3/4"
PAR25P	1"
PAR32P	1 1/4"
PAR40P	1 1/2"
PAR50P	2"
PAR65P	2 1/2"
PAR80P	3"
PAR100P	4"



U-BOLT

Cat.#	SIZE
CLU15P	1/2"
CLU20P	3/4"
CLU25P	1"
CLU32P	1 1/4"
CLU40P	1 1/2"
CLU50P	2"
CLU65P	2 1/2"
CLU80P	3"
CLU100P	4"

SOLUTIONS	CONC.	TEMP.	RECOMMENDED EXPOSURE			SOLUTIONS	CONC.	TEMP.	RECOMMENDED EXPOSURE		
			FUMES	SPLASH	LIQUID				FUMES	SPLASH	LIQUID
Acetic Acid	10%	75°F	YES	YES	NO	Malic Acid	Any	75°F	YES	YES	NO
Acid Copper Plating Sol.	Any	75°F	YES	YES	NO	Methyl Alcohol	Any	75°F	YES	YES	NO
Alkaline Cleaners	Any	75°F	YES	YES	NO	Mineral Oils	Any	75°F	YES	YES	YES
Aluminum Chloride	Sat'd	75°F	YES	YES	NO	Nickel Acetate	Sat'd	75°F	YES	YES	NO
Aluminum Sulfate	Sat'd	75°F	YES	YES	NO	Nickel Plating Solution	Any	75°F	YES	YES	NO
Alums	Sat'd	75°F	YES	YES	NO	Nickel Salts	Sat'd	75°F	YES	YES	NO
Ammonium Chloride	Sat'd	75°F	YES	YES	NO	Nitric Acid	35%	75°F	YES	YES	NO
Ammonium Hydroxide	28%	75°F	YES	YES	NO	Nitric Acid	40%	75°F	YES	YES	NO
Ammonium Hydroxide	10%	75°F	YES	YES	NO	Nitric Acid	60%	75°F	YES	YES	NO
Ammonium Sulfate	Sat'd	75°F	YES	YES	NO	Nitric/Hydrofluoric Acid	15%/4%	75°F	YES	YES	NO
Ammonium Thiocyanate	Sat'd	75°F	YES	YES	NO	Nitric Acid/Sodium		75°F	YES	YES	
Amyl Alcohol	Sat'd	75°F	YES	YES	YES	Dichromate/ Water	16%/13%/71%	75°F	YES	YES	NO
Arsenic Acids	Any	75°F	YES	YES	NO	Oleic Acid	Any	75°F	YES	YES	NO
Barium Sulfide	Sat'd	75°F	YES	YES	NO	Oxalic Acid	Any	75°F	YES	YES	NO
Black Liquor	Sat'd	75°F	YES	YES	NO	Phenol	Sat'd	75°F	YES	YES	NO
Benzoic Acid	Sat'd	75°F	YES	YES	NO	Phosphoric Acid	75%	75°F	YES	YES	NO
Brass Plating Solution	Sat'd	75°F	YES	YES	NO	Phosphoric Acid	85%	75°F	YES	YES	NO
Bromine Water	Sat'd	75°F	YES	YES	NO	Potassium Acid Sulfate	Sat'd	75°F	YES	YES	NO
Butyl Alcohol	Any	75°F	YES	YES	NO	Potassium Antimonate	Sat'd	75°F	YES	YES	NO
Cadmium Plating Sol.	Any	75°F	YES	YES	NO	Potassium Bisulfite	Sat'd	75°F	YES	YES	NO
Cadmium Bisulfate	Any	75°F	YES	YES	NO	Potassium Chloride	Sat'd	75°F	YES	YES	NO
Calcium Chloride	Sat'd	75°F	YES	YES	NO	Potassium Cuprocyanide	Sat'd	75°F	YES	YES	NO
Calcium Hypochlorite	Sat'd	75°F	YES	YES	NO	Potassium Cyanide	Sat'd	75°F	YES	YES	NO
Carbonic Acid	Sat'd	75°F	YES	YES	NO	Potassium Dichromate	Sat'd	75°F	YES	YES	NO
Casein	Any	75°F	YES	YES	NO	Potassium Hypochlorate	Sat'd	75°F	YES	YES	NO
Castor Oil	Any	75°F	YES	YES	YES	Potassium Sulfide	Sat'd	75°F	YES	YES	NO
Caustic Soda	35%	75°F	YES	YES	NO	Potassium Thiosulfate	Sat'd	75°F	YES	YES	NO
Caustic Soda	10%	75°F	YES	YES	NO	Propyl Alcohol	Sat'd	75°F	YES	YES	NO
Caustic Potash	35%	75°F	YES	YES	NO	Rhodium Plating Solution	Sat'd	75°F	YES	YES	NO
Caustic Potash	10%	75°F	YES	YES	NO	Silver Plating Solution	Sat'd	75°F	YES	YES	NO
Chlorine Water	Sat'd	75°F	YES	YES	NO	Soaps	Any	75°F	YES	YES	NO
Chromium Plating Sol.	Any	75°F	YES	YES	NO	Sodium Acid Sulfate	Sat'd	75°F	YES	YES	NO
Citric Acid	Sat'd	75°F	YES	YES	NO	Sodium Antimonate	Sat'd	75°F	YES	YES	NO
Copper Chloride	Sat'd	75°F	YES	YES	NO	Sodium Bicarbonate	Sat'd	75°F	YES	YES	NO
Copper Cyanide Plating Sol.	Any	75°F	YES	YES	NO	Sodium Bisulfite	Sat'd	75°F	YES	YES	NO
Copper Sulfate	Sat'd	75°F	YES	YES	NO	Sodium Chloride	Sat'd	75°F	YES	YES	NO
Coconut Oil	Sat'd	75°F	YES	YES	YES	Sodium Cyanide	Sat'd	75°F	YES	YES	NO
Cottonseed Oil	Sat'd	75°F	YES	YES	YES	Sodium Dichromate	Sat'd	75°F	YES	YES	NO
Disodium Phosphate	Sat'd	75°F	YES	YES	NO	Sodium Hydroxide	10%	75°F	YES	YES	NO
Ethyl Alcohol	Any	75°F	YES	YES	NO	Sodium Hydroxide	35%	75°F	YES	YES	NO
Ethylene Glycol	Any	75°F	YES	YES	YES	Sodium Hydroxide	73%	75°F	YES	YES	NO
Ferrous Sulfate	Sat'd	75°F	YES	YES	NO	Sodium Hypochlorite	Sat'd	75°F	YES	YES	NO
Fluoboric Acid	Any	75°F	YES	YES	NO	Sodium Hypochlorite	15%	75°F	YES	YES	NO
Formaldehyde	37%	75°F	YES	YES	NO	Sodium Sulfide	Sat'd	75°F	YES	YES	NO
Formic Acid	85%	75°F	YES	YES	NO	Sodium Thiosulfate	Sat'd	75°F	YES	YES	NO
Gallic Acid	Sat'd	75°F	YES	YES	NO	Sulfuric Acid	15%	75°F	YES	YES	NO
Glucose	Any	75°F	YES	YES	YES	Sulfuric Acid	50%	75°F	YES	YES	NO
Glycerine	Any	75°F	YES	YES	YES	Sulfuric Acid	70%	75°F	YES	YES	NO
Gold Plating Solution	Any	75°F	YES	YES	NO	Sulfuric Acid	98%	75°F	YES	YES	NO
Hydrochloric Acid	10%	75°F	YES	YES	NO	Sulfurous Acid	2%	75°F	YES	YES	NO
Hydrochloric Acid	21.5%	75°F	YES	YES	NO	Sulfurous Acid	4%	75°F	YES	YES	NO
Hydrochloric Acid	37.5%	75°F	YES	YES	NO	Tannic Acid	Sat'd	75°F	YES	YES	NO
Hydrofluoric Acid	4%	75°F	YES	YES	NO	Tartaric Acid	Sat'd	75°F	YES	YES	NO
Hydrofluoric Acid	10%	75°F	YES	YES	NO	Tin Chloride	Sat'd	75°F	YES	YES	NO
Hydrofluoric Acid	48%	75°F	YES	YES	NO	Tin Plating Solution	Sat'd	75°F	YES	YES	NO
Hydrogen Peroxide	30%	75°F	YES	YES	NO	Triethanolamine	Sat'd	75°F	YES	YES	NO
Hydroquinone	Any	75°F	YES	YES	NO	Trisodium Phosphate	Sat'd	75°F	YES	YES	NO
Indium Plating Solution	Any	75°F	YES	YES	NO	White Liquor	Sat'd	75°F	YES	YES	NO
Lactic Acid	Any	75°F	YES	YES	NO	Zinc Plating Solution	Sat'd	75°F	YES	YES	NO
Lead Plating Solution	Any	75°F	YES	YES	NO	Zinc Sulfate	Sat'd	75°F	YES	YES	NO

TECHNICAL INFORMATION

PVC EXTERIOR COATING CHEMICAL RESISTANCE CHART

SOLUTIONS	CONC.	TEMP.	RECOMMENDED EXPOSURE			SOLUTIONS	CONC.	TEMP.	RECOMMENDED EXPOSURE		
			FUMES	SPLASH	LIQUID				FUMES	FUMES	FUMES
Acetic Acid	10%	120	NO	NO	NO	Lactic Acid	50%	120	YES	YES	YES
Acid Copper Plating Sol.		160	YES	YES	YES	Lactic Acid	Any	90	YES	YES	YES
Alkaline Cleaners		160	YES	YES	YES	Lead Plating Solution	Any	150	YES	YES	YES
Aluminum Chloride	Sat'd	160	YES	YES	YES	Malic Acid	Any	90	YES	YES	YES
Aluminum Sulfate	Sat'd	160	YES	YES	YES	Methyl Alcohol	Any	90	YES	YES	YES
Alums	Sat'd	160	YES	YES	YES	Mineral Oils	Any	90	YES	YES	YES
Ammonium Chloride	Sat'd	160	YES	YES	YES	Nickel Acetate	Sat'd	160	YES	YES	YES
Ammonium Hydroxide	28%	120	YES	YES	YES	Nickel Plating Solution		160	YES	YES	YES
Ammonium Hydroxide	10%	120	YES	YES	YES	Nickel Salts	Sat'd	160	YES	YES	YES
Ammonium Sulfate	Sat'd	160	YES	YES	YES	Nitric Acid	35%	120	YES	YES	NO
Ammonium Thiocyanate	Sat'd	160	YES	YES	YES	Nitric Acid	40%	90	YES	YES	NO
Amyl Alcohol	Any	90	YES	YES	YES	Nitric Acid	60%	120	YES	YES	NO
Arsenic Acids	Any	150	YES	YES	YES	Nitric/Hydrofluoric Acid	15%/4%	140	YES	YES	YES
Barium Sulfide	Sat'd	160	YES	YES	YES	Nitric Acid/Sodium					
Black Liquor	Sat'd	90	YES	YES	YES	Dichromate/ Water	16%/13%/71%	130	YES	YES	YES
Benzoic Acid	Sat'd	160	YES	YES	YES	Oleic Acid	Any	90	YES	YES	YES
Brass Plating Solution	Any	160	YES	YES	YES	Oxalic Acid		90	YES	YES	YES
Bromine Water	Sat'd	120	YES	YES	YES	Phenol	Sat'd	120	NO	NO	NO
Butyl Alcohol	Any	90	YES	YES	YES	Phosphoric Acid	75%	150	YES	YES	YES
Cadmium Plating Sol.	Any	150	YES	YES	YES	Phosphoric Acid	85%	120	YES	YES	YES
Cadmium Bisulfate	Any	150	YES	YES	YES	Potassium Acid Sulfate	Sat'd	150	YES	YES	YES
Calcium Chloride	Sat'd	160	YES	YES	YES	Potassium Antimonate	Sat'd	150	YES	YES	YES
Calcium Hypochlorite	Sat'd	120	YES	YES	YES	Potassium Bisulfite	Sat'd	90	YES	YES	YES
Carbonic Acid	Sat'd	160	YES	YES	YES	Potassium Chloride	Sat'd	160	YES	YES	YES
Casein	Any	90	YES	YES	YES	Potassium Cuprocyanide	Sat'd	150	YES	YES	YES
Castor Oil	Any	90	YES	YES	YES	Potassium Cyanide	Sat'd	160	YES	YES	YES
Caustic Soda	35%	120	YES	YES	YES	Potassium Dichromate	Sat'd	160	YES	YES	YES
Caustic Soda	10%	150	YES	YES	YES	Potassium Hypochlorate	Sat'd	90	YES	YES	NO
Caustic Potash	35%	120	YES	YES	YES	Potassium Sulfide	Sat'd	150	YES	YES	YES
Caustic Potash	10%	150	YES	YES	YES	Potassium Thiosulfate	Sat'd	150	YES	YES	YES
Chlorine Water	Sat'd	90	YES	YES	YES	Propyl Alcohol	Sat'd	150	YES	YES	YES
Chromium Plating Sol.	Any	150	YES	YES	YES	Rhodium Plating Solution	Sat'd	150	YES	YES	YES
Citric Acid	Sat'd	160	YES	YES	YES	Silver Plating Solution	Sat'd	150	YES	YES	YES
Copper Chloride	Sat'd	160	YES	YES	YES	Soaps	Any	90	YES	YES	YES
Copper Cyanide Plating Sol.	Any	160	YES	YES	YES	Sodium Acid Sulfate	Sat'd	160	YES	YES	YES
(High Speed)	Any	180	YES	YES	YES	Sodium Antimonate	Sat'd	150	YES	YES	YES
(with Alkali Cyanides)	Sat'd	160	YES	YES	YES	Sodium Bicarbonate	Sat'd	160	YES	YES	YES
Copper Sulfate	Sat'd	160	YES	YES	YES	Sodium Bisulfite	Sat'd	90	YES	YES	YES
Coconut Oil	Sat'd	90	YES	YES	YES	Sodium Chloride	Sat'd	160	YES	YES	YES
Cottonseed Oil	Sat'd	90	YES	YES	YES	Sodium Cyanide	Sat'd	160	YES	YES	YES
Disodium Phosphate	Sat'd	160	YES	YES	YES	Sodium Dichromate	Sat'd	160	YES	YES	YES
Ethyl Alcohol	Any	90	YES	YES	YES	Sodium Hydroxide	10%	150	YES	YES	NO
Ethylene Glycol	Any	90	YES	YES	NO	Sodium Hydroxide	35%	120	YES	YES	NO
Ferric Chloride	45%	120	YES	YES	YES	Sodium Hydroxide	73%	160	NO	NO	NO
Ferrous Sulfate	Sat'd	150	YES	YES	YES	Sodium Hypochlorite	Sat'd	90	YES	YES	NO
Fluoboric Acid	Any	150	YES	YES	YES	Sodium Hypochlorite	15%	120	YES	YES	NO
Formaldehyde	37%	120	YES	YES	YES	Sodium Sulfide	Sat'd	150	YES	YES	YES
Formic Acid	85%	100	NO	NO	NO	Sodium Thiosulfate	Sat'd	150	YES	YES	YES
Gallie Acid	Sat'd	150	YES	NO	NO	Sulfuric Acid	15%	120	YES	YES	YES
Glucose	Any	150	YES	YES	YES	Sulfuric Acid	50%	120	YES	YES	YES
Glycerine	Any	90	YES	YES	YES	Sulfuric Acid	70%	90	YES	YES	NO
Gold Plating Solution	Any	150	YES	YES	YES	Sulfuric Acid	98%	100	YES	NO	NO
Hydrochloric Acid	10%	120	YES	YES	YES	Sulfurous Acid	2%	120	YES	YES	NO
Hydrochloric Acid	21.5%	120	YES	YES	YES	Sulfurous Acid	6%	120	YES	YES	NO
Hydrochloric Acid	37.5%	120	YES	YES	NO	Tannic Acid	Sat'd	90	YES	YES	YES
Hydrochloric Acid	37.5%	90	YES	YES	NO	Tartaric Acid	Sat'd	90	YES	YES	YES
Hydrofluoric Acid	4%	140	YES	YES	NO	Tin Chloride	Sat'd	150	YES	YES	YES
Hydrofluoric Acid	10%	120	YES	YES	NO	Tin Plating Solution	Sat'd	150	YES	YES	YES
Hydrofluoric Acid	48%	120	YES	YES	NO	Triethanolamine	Sat'd	150	YES	YES	YES
Hydrogen Peroxide	30%	120	YES	YES	YES	Trisodium Phosphate	Sat'd	150	YES	YES	YES
Hydrogen Sulfide	Sat'd	120	YES	YES	YES	White Liquor	Sat'd	90	YES	YES	YES
Hydroquinone	Any	90	YES	YES	YES	Zinc Plating Solution		160	YES	YES	YES
Indium Plating Solution	Any	150	YES	YES	YES	Zinc Sulfate	Sat'd	160	YES	YES	YES

Section 3 — External Coatings

3.1 Thickness

The thickness of polyvinyl chloride (PVC) coatings shall be a nominal 0.040 in. (1.02 mm). The tolerance on the coating thickness shall be +0.010 in. (0.25 mm) or -0.005 in. (0.13 mm).

3.2 Coating Material

Properties of PVC Coatings — Table 3.1

PROPERTY	MINIMUM REQUIREMENT	ASTM TEST METHOD
Hardness:		
Shore A	75	D 2240
Shore D	25	D 2240
Tensile Strength	2,000 psi	D 638
Elongation	200%	D 638
Dielectric strength	325 volts per mil	D 149
Brittleness temperature	5° F	D 1790

3.3 Application of Coating

3.3.1 Cleaning

The exterior surface that is to receive the coating shall be free of grease, oil, dirt and other extraneous matter. The surface shall be cleaned in such a manner that the galvanized surface of the conduit is not harmed or eroded.

3.3.2 Priming

The cleaned exterior surface shall be primed with an adhesive suitable for use with the PVC coating material to be applied.

3.3.3 Coating

The PVC material shall be applied in powder, plastisol or pellet form by a manufacturing method which will produce a finished product conforming to these standards.

3.4 Elbows

Coated elbows shall be used with coated conduit. The thickness of the coating on elbows shall be in accordance with Section 3.1.

3.5 Couplings

Coated couplings shall be used with coated conduit. The thickness of the coating on couplings shall be at least equal to the thickness of the coating on the conduit.

Each coated coupling shall have a flexible PVC sleeve which extends from each end of the coupling and which will overlap the PVC coating on the conduit when the coupling has been installed on the conduit.

The length of the sleeve extension(s) shall be at least equivalent to the nominal conduit size for sizes up through NPS 2 (53). For sizes NPS 2 1/2 (63) through NPS 6 (155), the length of the sleeve extension(s) shall be at least 2 in. (50.8 mm).

The PVC sleeve shall be a nominal thickness of 0.040 in. (1.02 mm). The inside diameter (I.D.) of the overlapping sleeve shall be less than the outside diameter (O.D.) of the PVC-coated conduit.

3.6 Workmanship and Appearance

The PVC coating shall be free of blisters, bubbles, and pinholes. The PVC coating shall be continuous over the entire length of the conduit except at the threads and shall be holiday-free at the time of manufacture.

A holiday is herein defined as an electrical discontinuity of less than 80,000 ohms equivalent resistance sensed with a cellulose sponge wet with a suitable electrolyte and measured with an appropriate low voltage direct-current instrument. A suitable electrolyte is a solution containing tap water, 3.0% salt (sodium chloride) and 0.5% liquid detergent.

The inside of the PVC-coated conduit, couplings and elbows shall be free of the PVC coating material.

All sleeve extensions shall be square cut.

3.7 Performance Requirements

Typical physical requirements for PVC-coated conduit are given in

Table 3-2.

Typical Physical Properties of PVC-Coated Rigid Conduit and IMC — Table 3.2

PROPERTY	REQUIREMENT*	TEST METHOD
Abrasion resistance	200 hours, no failure	ASTM G6
Bendability, radius (at 73.4° ± 1.8° F)	9 in. (228.6 mm)	ASTM G10
Artificial weathering	Minimum 1,000 hours, no adverse effect	ASTM G153

* The above requirements are based on testing a 0.040 in. (1.02 mm) PVC coating applied over NPS 3/4 inch (21) galvanized rigid steel conduit. See Section 1 for information on the ASTM test methods.

3.8 Adhesion

The adhesion of the PVC coating to the conduit shall be greater than the strength of the coating itself. This shall be determined by making

two circumferential cuts, above 1/2 in. (12.7 mm) apart, through the plastic to the substrate. A third cut shall be made perpendicular to and crossing the circumferential cuts. The edge of the plastic shall be carefully lifted with a knife to form a plastic tab. This tab shall be pulled perpendicular

to the conduit with a pair of pliers. The plastic tab shall tear rather than any additional coating film separating from the substrate