

Conduit Unions

Description:

Procoat UNF unions are used to connect conduit to conduit or to allow for future changes to the conduit system. Female threads are provided at each end. Procoat UNY unions are used to connect conduit to a conduit fitting, junction box, or device enclosure. One end is a male thread and the other is female.

Features:

- 40 mil gray PVC exterior coating
- 2 mil gray urethane interior coating
- 13 trade sizes from 1/2" through 6"
- Sealing sleeves on all conduit openings
- Molded PVC gasket seals fitting

Standards:

- NEC/CEC:
- UNF/UNY 1/2" through 1"
Class I, Division 1 & 2, Groups A, B, C, D
Class II, Division 1, Groups E, F, G
Class II, Division 2, Groups F, G
Class III
- UNF/UNY 905, 1005
Class I, Division 1 & 2, Groups B, C, D
Class II, Division 1, Groups E, F, G
Class II, Division 2, Groups F, G
Class III
- UNF, UNY - all sizes
Class I, Division 1 & 2, Groups C, D
Class II, Division 1, Groups E, F, G
Class II, Division 2, Groups F, G
Class III

Conduit Union Technical Data

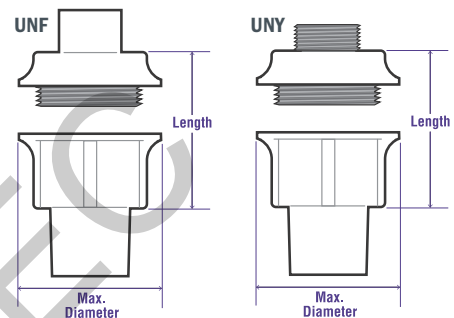

UNF

PIPE SIZE	FERROUS CATALOG #	NOMINAL WEIGHT	LENGTH	MAX DIA.	ALUMINUM CATALOG #
1/2"	UNF15P	0.3	1.81	2.00	UNF15AP
3/4"	UNF20P	0.5	1.75	2.25	UNF20AP
3/4" - 1/2"	UNF215P	0.6	1.75	2.25	-
1"	UNF25P	0.7	2.00	2.75	UNF25AP
1-1/4"	UNF32P	1.5	2.25	3.00	UNF32AP
1-1/2"	UNF40P	2.3	2.63	3.50	UNF40AP
2"	UNF50P	3.6	2.56	4.50	UNF50AP
2-1/2"	UNF65P	5.0	3.19	4.75	UNF65AP
3"	UNF80P	6.5	3.44	5.50	UNF80AP
3-1/2"	UNF90P	8.2	4.13	6.50	UNF90AP
4"	UNF100P	10.0	4.13	7.00	UNF100AP
5"	UNF125P	12.5	3.81	9.00	-
6"	UNF150P	14.8	3.81	10.25	-

UNY

PIPE SIZE	FERROUS CATALOG #	NOMINAL WEIGHT	LENGTH	MAX DIA.	ALUMINUM CATALOG #
1/2"	UNY15P	0.4	2.38	2.00	UNY15AP
3/4"	UNY20P	0.7	2.44	2.25	UNY20AP
3/4" - 1/2"	UNY215P	0.8	2.44	2.25	-
1"	UNY25P	1.3	2.75	2.75	UNY25AP
1-1/4"	UNY32P	2.6	3.19	3.00	UNY32AP
1-1/2"	UNY40P	3.9	3.56	3.50	UNY40AP
2"	UNY50P	4.2	3.75	4.50	UNY50AP
2-1/2"	UNY65P	5.5	4.63	4.75	UNY65AP
3"	UNY80P	7.5	5.00	5.50	UNY80AP
3-1/2"	UNY90P	8.4	5.50	6.50	UNY90AP
4"	UNY100P	10.5	5.63	7.00	UNY100AP
5"	UNY125P	12.0	5.25	9.00	-
6"	UNY150P	14.9	5.38	10.25	-