



PVC Coated Elbows

Description:

Procoat factory bent standard radius elbows are available and ready to ship. Factory bent elbows are more accurate, quicker to install, and more economical, because they save field bending time and do not waste materials. Electrical continuity is maintained across assembled joints.

Features:

- 40 mil gray PVC exterior coating
- 2 mil gray urethane interior coating
- 12 trade sizes from 1/2" through 6"
- Available in standard sizes 90°, 60°, 45°, 30° bends
- Plastic thread protector caps are color coded for quick identification of conduit size.

Thread Protector Cap Colors:

Black - for 1/2" sizes, 1/2", 1-1/2", 2-1/2", 3-1/2"

Red - for 1/4" sizes, 3/4", 1-1/4"

Blue - for even sizes, 1", 2", 3", 4", 5", 6"

Standards:

Steel and Aluminum

- UL 6 (E2314); UL 6A (E98405)
- CSA C22.2 No. 45
- Both PVC and zinc coatings have been investigated as primary protection against corrosion. Restricted for use with threaded fittings only.

Dimensions

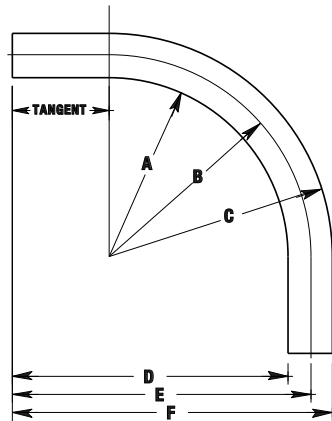

DIAGRAM LEGEND

- A = Radius at inside of bend.
- B = Radius at center line of bend.
- C = Radius at outside of bend.
- D = Offset at inside of bend.
- E = Offset at center of bend.
- F = Offset at outside of bend.

Standard Radius Elbows

METRIC SIZE DESIGNATORS	NOMINAL SIZE INCHES	DIAMETERS		NIPPLE LENGTHS INCHES	RADIO (STANDARD)			OFFSET			TANGENT INCHES
		EXTERNAL INCHES	INTERNAL INCHES		A INCHES	B INCHES	C INCHES	D INCHES	E INCHES	F INCHES	
RSCE9015P	1/2"	0.920"	0.632"	11-1/4"	3.79"	4.25"	4.71"	6.040"	6.500"	6.960"	2.250"
RSCE9020P	3/4"	1.130"	0.836"	12-1/2"	3.94"	4.50"	5.07"	6.685"	7.250"	7.815"	2.750"
RSCE9025P	1"	1.395"	1.063"	14-3/4"	5.05"	5.75"	6.45"	7.928"	8.625"	9.323"	2.875"
RSCE9032P	1-1/4"	1.740"	1.394"	17-3/4"	6.38"	7.25"	8.12"	9.567"	10.437"	11.307"	3.187"
RSCE9040P	1-1/2"	1.980"	1.624"	19-3/4"	7.26"	8.25"	9.24"	10.635"	11.625"	12.615"	3.375"
RSCE9050P	2"	2.455"	2.083"	22-1/2"	8.27"	9.50"	10.73"	12.086"	13.313"	14.541"	3.813"
RSCE9065P	2-1/2"	2.955"	2.489"	28"	9.02"	10.50"	11.98"	14.776"	16.253"	17.731"	5.753"
RSCE9080P	3"	3.580"	3.080"	32"	11.21"	13.00"	14.79"	17.000"	18.790"	20.580"	5.790"
RSCE9090P	3-1/2"	4.080"	3.570"	39-1/2"	12.96"	15.00"	17.04"	20.920"	22.960"	25.000"	7.960"
RSCE90100P	4"	4.580"	4.050"	39-1/2"	13.71"	16.00"	18.29"	20.890"	23.180"	25.470"	7.180"
RSCE90125P	5"	5.643"	5.073"	59-1/2"	21.18"	24.00"	26.82"	32.079"	34.900"	37.722"	10.900"
RSCE90150P	6"	6.705"	6.093"	76"	26.65"	30.00"	33.35"	41.088"	44.440"	47.793"	14.440"

Special Radius Elbows

Procoat factory bent elbows are also available in larger than standard radii to accommodate your special needs. Simply follow the four steps for standard radius elbows on the previous page, then continue with Steps 5 and 6 for large radius elbows. Refer to the table below to determine which radius is available for the size of conduit you need.

To use the Long or Special Radius Elbow table, find the elbow radius required in the first row. Then look down the column to determine which conduit sizes are available in that radius. Use this information in Steps 5 and 6 on the previous page to build a catalog number.

Radius B in Inches	12"	15"	18"	18"	24"	24"	30"	30"	36"	36"	36"	42"	42"	48"	48"	48"
E Offset	1'5-1/2"	1'9-1/4"	2'1/4"	2'3"	2'8"	2'10"	3'4"	3'5"	3'11"	3'11-1/4"	4'3-1/4"	4'5"	4'6"	5'1/4"	5'1-1/4"	5'3-1/4"
Nipple Length	2'6"	3'0"	3'5"	3'10"	4'6"	4'9"	5'6"	5'9"	6'7"	6'7"	7'3"	7'4"	7'6"	8'4"	8'6"	8'10"
Tangent	5-1/2"	6-1/4"	6-1/4"	9"	8"	10"	10"	11"	11"	11-1/4"	15-1/4"	11"	12"	12-1/4"	13-1/4"	15-1/4"
Available Pipe & Sizes	1" to 2"	2"	1"	1-1/2" to 3"	3/4" to 2"	2-1/2" to 5"	2" to 3"	4" to 5"	3/4" to 4"	5"	6"	4"	5"	1-1/2" to 4"	5"	6"